

PRODUCT DATA SHEET

Product Description: Surface vertical rod exit device, for 28" to 42" wide doors. UL10C 3 hour fire rated, ANSI A156.3 Grade 1. Non handed. Rail and push pad are fabricated from heavy gauge steel with a powder coated aluminum finish. Trim available in the following functions: classroom, storeroom, passage and dummy. Device and trim for 161 standard cut out. Mounting hardware and 239 strike included. ADA compliant.

Designed For 161 Cut Out Door Prep

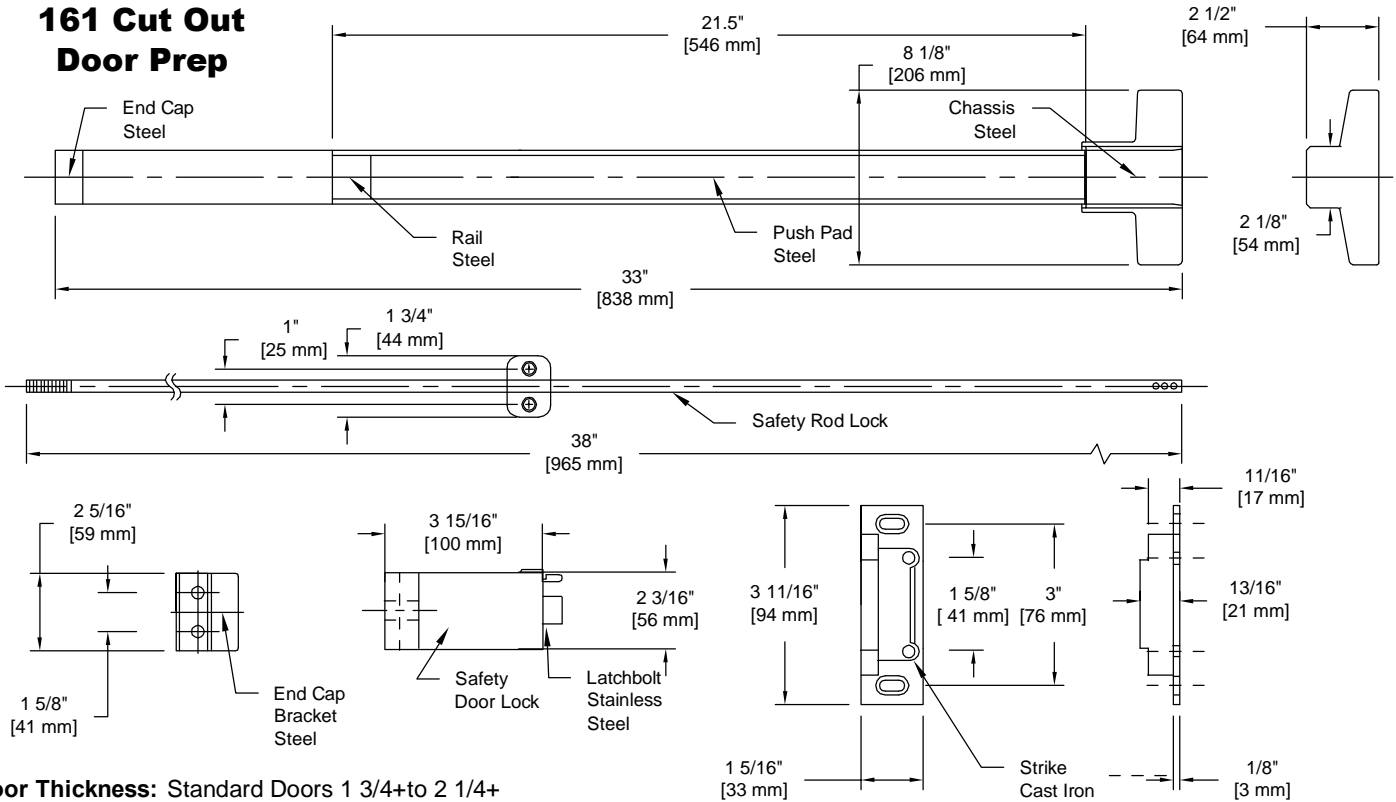

Door Thickness: Standard Doors 1 3/4" to 2 1/4"

Latch Bolt: Stainless Steel 3/4" Throw

Strike: 239 Standard

ANSI/BHMA: Exit Device: A156.3 Grade 1



Overall Size: 33" W X 8 1/8" H X 2 1/2" D

Material: Steel, Cast Iron, Stainless Steel

Finish: Powder Coated Aluminum

Cross Reference

Manufacturer	Part Number
CAL-ROYAL	F2260

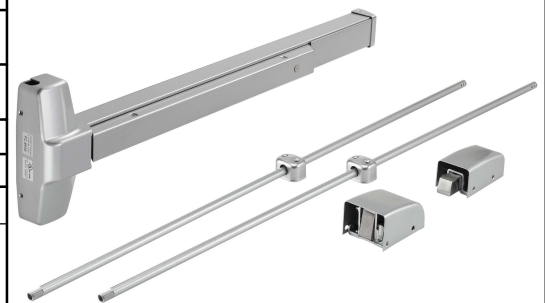

Description:

Surface Vertical Rod Exit Device, Fire Rated, 32", UL10C, ANSI Grade 1

Part Number:

PE55003684VFP

Date

09/16

Rev.

04

Sheet 1 of 1