

PRODUCT DATA SHEET

Product Description: Economy handrail bracket. Fabricated from zinc with a US15 satin nickel finish. Ships with mounting hardware.

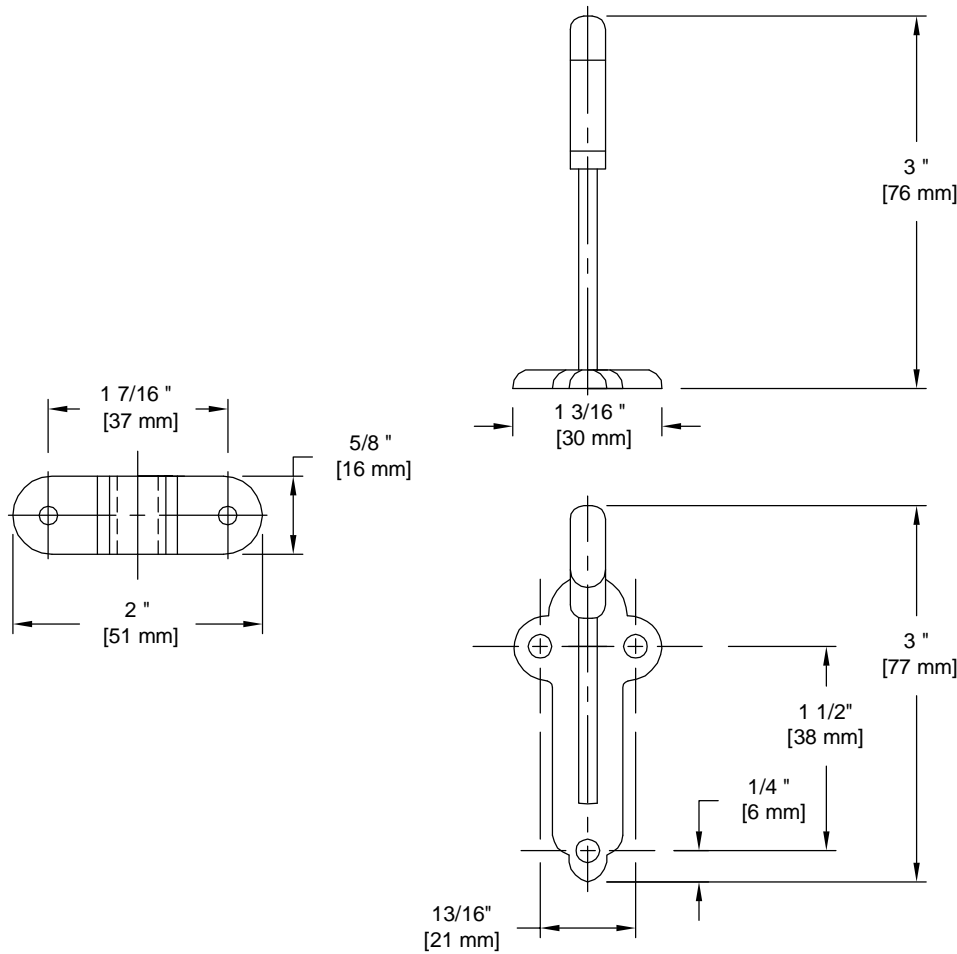

Overall Size: 1 3/16" W X 3" H X 3" D

Material: Zinc

Finish: US15 Satin Nickel

Cross Reference

Manufacturer	Part Number



Description:

**Handrail Bracket, Zinc,
Economy**

Part Number:

33606

Date

06/16

Rev.

04

Sheet 1 of 1